

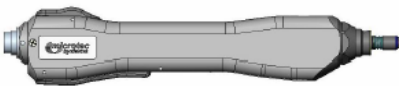

Model	Torque								RPM		Encodori	Transducer	G4	Body Style
	Ncm		Nm		inlbs		inoz							
	min	max	min	max	min	max	min	max	min	max				
RS05	0,5	5	0.005	0.05	0.04	0.44	0.7	7.0	100	600	Yes	Yes	Yes	P
RS10	1	10	0.01	0.1	0.08	0.88	1.4	14.2	100	600	Yes	Yes	Yes	P
RS20	2	20	0.02	0.2	0.17	1.77	2.8	28.3	100	800	Yes	Yes	Yes	P
RS50	5	50	0.05	0.5	0.44	4.42	7.0	70.8	100	1000	Yes	Yes	Yes	P
RS80	8	80	0.08	0.8	0.7	7.08	11.3	113.2	100	1200	Yes	Yes	Yes	P
RS100	10	100	0.1	1	0.88	8.85	14.2	142.0	100	1000	Yes	Yes	Yes	P
RS200	20	200	0.2	2	1.77	17.7			100	700	Yes	Yes	Yes	P
RS500	50	500	0.5	5	4.42	44.2			100	600	Yes	Yes	Yes	P
RS1000	100	1000	1	10	8.85	88.5			100	800	Yes	Yes	Yes	P
RS2000	200	2000	2	20	17.7	177			100	450	Yes	Yes	Yes	P
MD03	0,5	2,5	0.005	0.025	0.044	0.22	0.7	3.5	100	600	No	No	No	A
MD05	1,5	5	0.01	0.05	0.13	0.44	2.1	7.0	350	700	No	No	No	A
MD10	3	10	0.03	0.1	0.265	0.88	4.2	14.2	350	700	No	No	No	A
MD25	7,5	25	0.07	0.25	0.66	2.21	10.6	35.4	500	800	Yes	No	No	B
MD50L	15	50	0.15	0.5	1.32	4.42	21.2	70.8	100	1000	Yes	No	Yes	L
MD80L	16	80	0.16	0.8	1.14	7.08			100	1200	Yes	No	Yes	L
MD100L	25	100	0.25	1	2.21	8.85			100	1000	Yes	No	Yes	L
MD250L	50	200	0.5	2.5	7	22			350	700	Yes	No	Yes	L
MD400L	150	400	1.15	4	13.27	35.4			300	600	Yes	No	Yes	L
MD05P	1,5	5	0.01	0.05	0.13	0.44	0.7	7.0	100	1000	Yes	No	Yes	P
MD10P	3	10	0.03	0.1	0.265	0.88	4.2	14.2	100	1000	Yes	No	Yes	P
MD20P	5	20	0.05	0.2	0.44	1.77	7.0	28.3	100	800	Yes	No	Yes	P
MD50P	15	50	0.15	0.5	1.32	4.42	21.2	70.8	100	1000	Yes	No	Yes	P
MD80P	16	80	0.16	0.8	1.14	7.08			100	1200	Yes	No	Yes	P
MD100P	25	100	0.25	1	2.21	8.85			100	1000	Yes	No	Yes	P
MD200P	50	200	0.5	2	4.42	17.7			100	600	Yes	No	Yes	P
MD400P	150	400	1.15	4	13.27	35.4			100	500	Yes	No	Yes	P
MD800P	300	800	3	8	26	70			100	400	Yes	No	Yes	P

Body Style

- A MD 03, MD 05, MD 10
Manual Screwdrivers 
- B MD 25
Manual Screwdriver 
- L MD 50 L, MD 80 L,
MD 100 L, MD 200 L
Ergonomic Body
manual screwdrivers
(„L“-Versions) 
- P MD 05 P, MD 10 P, MD
20 P, MD 50 P, MD 100
P, MD 80 P, MD 200 P,
MD 400 P, MD 800 P
Screwdrivers for
Automation
(„P“-Versions) 